

Installation

Refer to the illustration below for the recommended mounting positions. When selecting an appropriate mounting position, keep in mind the potential for air drafts or objects to be passed through gaps around the door and into the detection area.

The cable entry opening into the T.Rex is on the right back side, near the cover retaining screw. There is a recess in the back of the T.Rex to allow wires to be routed from any point behind the T.Rex to the cable entry opening.

First, remove the cover, then remove the detector barrel from the back casing by rotating

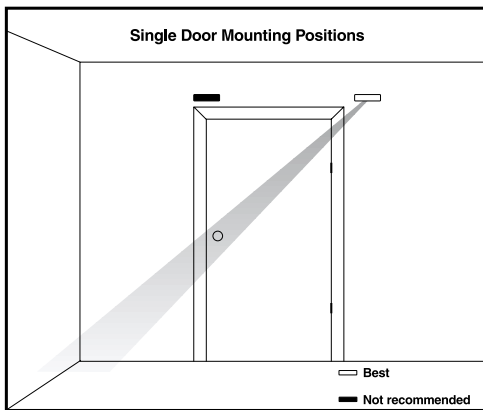
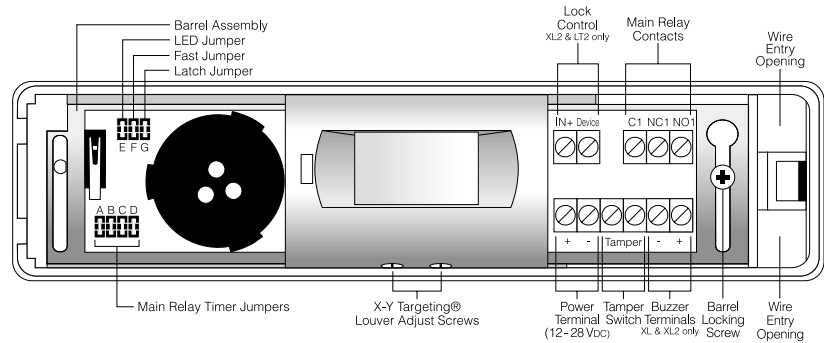

the barrel upward. Route the wiring into the back casing. Next, mount the back casing to the wall. Install the detector barrel into the back casing and connect the wiring. This is a good time to modify the jumper settings if necessary; the jumper settings are explained on the next page. Make sure that the barrel is free to rotate, to permit final adjustment. Replace the cover, left end first (the end with 2 hooks).

Jumper Settings

There are a total of 7 jumpers on the left side of the circuit board. By default, all jumpers are ON.

LED Jumper

This jumper selects whether or not the LED changes color when the main relay is activated. By default, the LED is enabled to follow the relay activation.

Fast Jumper

This jumper selects between normal and high sensitivity. When set to high sensitivity (the default), the LED is normally red, and turns green when the main relay is activated. This mode is recommended for exit detector use.

When normal sensitivity is selected, the LED is normally green, and turns red when the relay is activated (selecting normal sensitivity allows the T.Rex to be used in unsteady environments).

Latch Jumper

This jumper determines the relay operation: in Latch mode (the default), the relay activates for the duration of the main relay timer setting whenever someone is detected.

In Follow mode (jumper removed), the relay stays on only as long as there is activity in the detection zone, but up to a maximum time equal to the main relay timer setting.

Technical Specifications	
Detector type	Passive Infrared
Filter technology	Digital Signal Processing (D.S.P.)
Detector lens	Curtain type Fresnel lens
Detection range	One hand: 3m (10 ft.) / Whole body: 6m (20 ft.)
Power consumption	12-28 volts DC, 50 mA
Piezo buzzer	90 dB at 28V, 5-28 volts DC, 20 mA. (XL & XL2 only)
Main relay contacts	SPDT, 1A max. at 30 volts DC max.
Main relay timer	Adjustable, 1/2 to 60 seconds
Main relay recycle time	Fixed, 3/4 second off
Lock control relay	N.C. 2A max at 30 volts DC Time fixed at 2 seconds (LT2 & XL2 only)
Tamper switch	N.C., 100mA max at 30 volts DC max.
Dimensions	19cm L x 4.5cm W x 4.75cm D 7-1/8"L x 1-3/4"W x 1-7/8"D
Indicator light	Red/Green LED
Certification	UL-294, CE, FCC

Main Relay Timer Jumpers

The duration of the relay ON time (Latch mode) or the maximum main relay ON time (Follow mode), is set by these jumpers, found on the lower left side of the circuit board. 16 different times can be selected according to the main relay timer setting table, ranging from 1/2 second to 60 seconds. The default setting is 2 seconds.

In both Latch and Follow modes, when the main relay turns off again, it will stay off for 3/4 second. This is to ensure that the access control panel does not miss brief changes of state.

Time (seconds)	Jumper			
	A	B	C	D
1/2				
1				
2				
3				
4				
5				
6				
8				
10				
15				
20				
25				
30				
40				
50				
60				

■ Jumper ON.

Top Three Jumpers		
Jumper	Jumper On (Factory Default)	Jumper Off
LED	LED follows relay.	LED stays on.
Fast	High sensitivity, LED normally red, LED green on detection.	Normal sensitivity, LED normally green, LED red on detection.
Latch	Relay stays on for timer setting.	Relay follows detection, up to maximum of timer setting.

Lock Control Relay (LT2 and XL2 only)

The lock control relay is deactivated (open contact) after 2 seconds on a detection.

Power-up Test

The LED will flash twice quickly every second while the T.Rex goes through its power-up diagnostic sequence (about 40 seconds) after which the T.Rex is ready to operate normally. If trouble is detected at any time, the LED will begin to flash rapidly 4 times per second. If the T.Rex is upset by a strong power fluctuation, it will resume normal operation after a 10 second self test.

Detection Pattern Adjustment

Once the T.Rex is installed and the cover replaced, the span and target direction of the detection pattern is set by gently turning the louver direction screws, located just below the detector lens on the barrel. As the adjustment range is about 45°, you must be careful not to turn the louvers too far; stop turning when resistance is felt. The slots on the louver adjusting screws indicate the position of the louver and serve as an adjustment guide. To adjust the detection zone toward or away from the door, simply rotate the detector barrel as required. When the T.Rex is mounted directly above the door, it is recommended that the detection area be directed away from the door. Rotate the barrel slightly away from the door, so that the lower edge of the detector lens is about 1/4" above the edge of the case. Check that the detection pattern is adequate by walk testing. Watch the LED for position detection. When you are satisfied with the detection pattern, remove the cover and tighten the barrel locking screw on the right side of the barrel, and replace the cover.

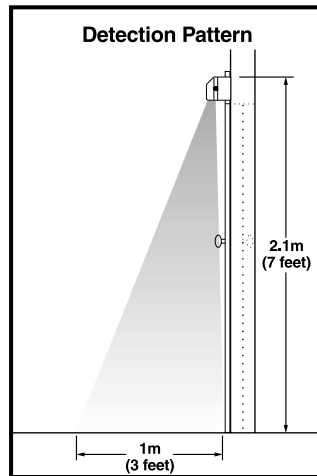

Part No.	Description
DSC-TREX-LT	No piezo buzzer
DSC-TREX-XL	With piezo buzzer
DSC-TREX-LT2	No piezo buzzer with Lock Control Relay
DSC-TREX-XL2	With piezo buzzer and Lock Control Relay

Limited Warranty

Digital Security Controls Ltd. warrants that for a period of 12 months from the date of purchase, the product shall be free of defects in materials and workmanship under normal use and that in fulfillment of any breach of such warranty, Digital Security Controls Ltd. shall, at its option, repair or replace the defective equipment upon return of the equipment to its repair depot. This warranty applies only to defects in parts and workmanship and not to damage incurred in shipping or handling, or damage due to causes beyond the control of Digital Security Controls Ltd. such as lightning, excessive voltage, mechanical shock, water damage, or damage arising out of abuse, alteration or improper application of the equipment.

The foregoing warranty shall apply only to the original purchaser, and is and shall be in lieu of any and all other warranties, whether expressed or implied and of all other obligations or liabilities on the part of Digital Security Controls Ltd. Digital Security Controls Ltd. neither assumes responsibility for, nor authorizes any other person purporting to act on its behalf to modify or to change this warranty, nor to assume for it any other warranty or liability concerning this product.

In no event shall Digital Security Controls Ltd. be liable for any direct, indirect or consequential damages, loss of anticipated profits, loss of time or any other losses incurred by the buyer in connection with the purchase, installation or operation or failure of this product.

Motion detectors can only detect motion within the designated areas as shown in their respective installation instructions. They cannot discriminate between intruders and intended occupants. Motion detectors do not provide volumetric area protection. They have multiple beams of detection and motion can only be detected in unobstructed areas covered by these beams. They cannot detect motion which occurs behind walls, ceilings, floor, closed doors, glass partitions, glass doors or windows. Any type of tampering whether intentional or unintentional such as masking, painting, or spraying of any material on the lenses, mirrors, windows or any other part of the detection system will impair its proper operation.

Passive infrared motion detectors operate by sensing changes in temperature. However their effectiveness can be reduced when the ambient temperature rises near or above body temperature or if there are intentional or unintentional sources of heat in or near the detection area. Some of these heat sources could be heaters, radiators, stoves, barbecues, fireplaces, sunlight, steam vents, lighting and so on.

Warning: Digital Security Controls Ltd. recommends that the entire system be completely tested on a regular basis. However, despite frequent testing, and due to, but not limited to, criminal tampering or electrical disruption, it is possible for this product to fail to perform as expected.

Important Information: Changes or modifications not expressly approved by Digital Security Controls Ltd. could void the user's authority to operate this equipment.

WARNING: This detector provides fast detection and has not been designed to be used in intrusion detection applications. This detector is designed to detect an individual approaching a door. Normally, upon receiving the detector information, the system supervising the door will bypass the door condition for a certain time to permit the exit without causing an alarm. This detector is designed to be used on free exit doors. It has not been designed to unlock doors. Locking and associated devices are generally governed by regulatory bodies and should always be installed according to local regulations. In most instances there are strict limitations to installing this type of device on doors used to exit. Be sure to check with local authorities for regulations before using any such devices.

This device complies with Part 15 of the FCC Rules. Operation is subject to the following two conditions: (1) This device may not cause harmful interference, and (2) this device must accept any interference received, including interference that may cause undesired operation. Changes or modifications not expressly approved by DSC could void the user's authority to use this equipment.



©2002 Digital Security Controls Ltd.
 Toronto, Canada • www.dsc.com
 Technical Support (North America): 1-800-387-3630
 Printed in Canada 29004104 R003